

**IR SEEKER VITAL INFORMATION**

**IRSEEKERV2 CHARACTERISTICS**

The documentation for the IRSeekerV2 from Hitechnic displays the sensing Zones as symmetrical areas around the sensor.

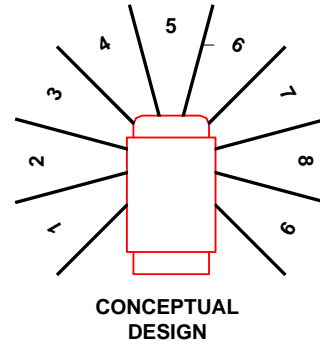

These zones conceptually depict the areas of direct sensing and overlap sensing that the five infrared detectors within the sensor are capable of.

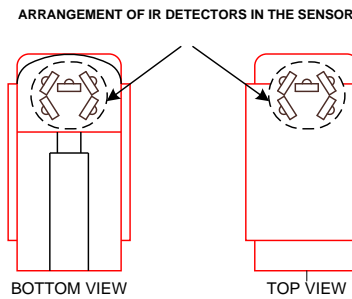

A more accurate conceptual depiction of the Zones for the IRSeekerV2 sensor is presented here.

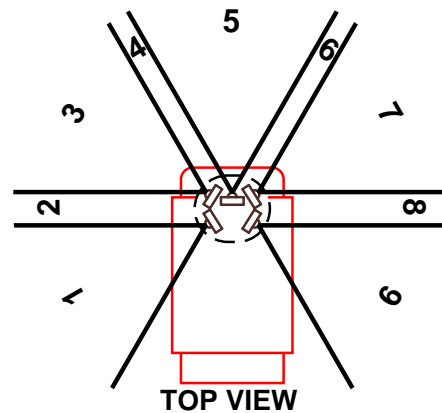

A method to get the most precise radial position reading from the sensor may be to use the intersection where two of the detectors are detecting the IR source.

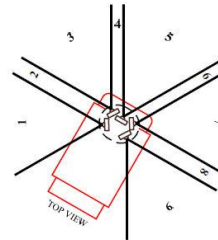
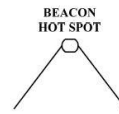

As you can see from the graph section below, it may not be reasonable to use a zone based on a single detector. A zone based on two detectors may offer the best precision if the Intensity values are used.

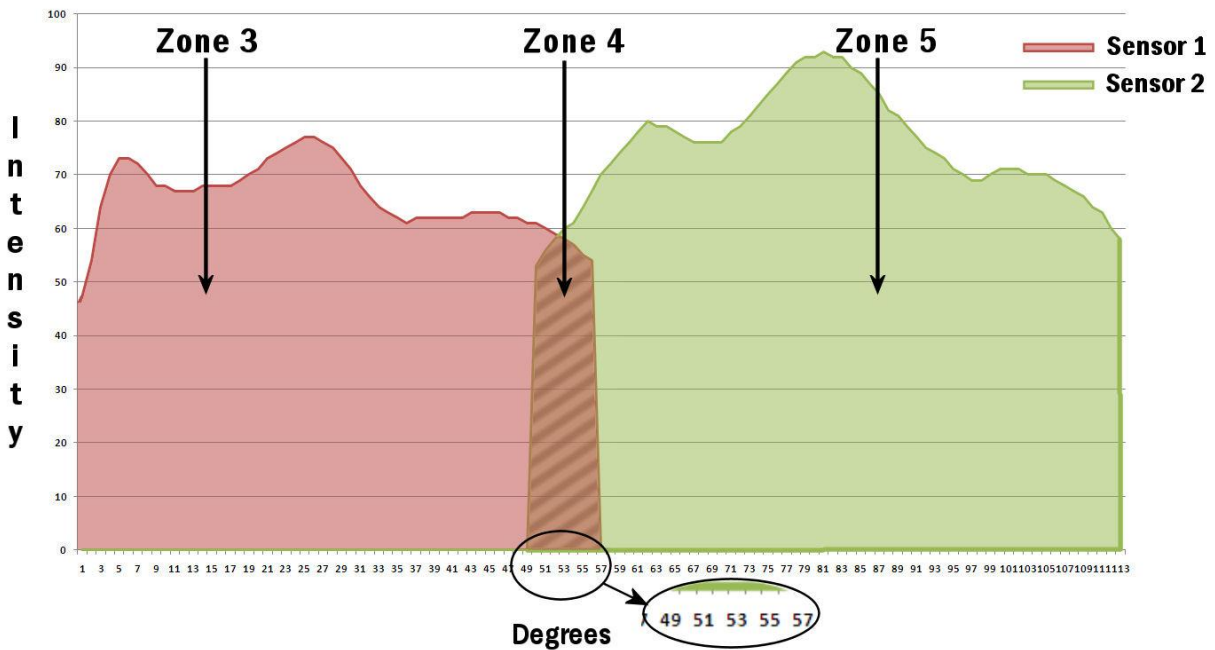

Included as an attachment to this document is an [Excel spreadsheet](#) showing the sensor readings in 1° increments starting at the first detected signal reading and ending at the last detected signal reading. The waveform distortion exhibited is a result of the signal passing through the lens as well as misalignment between the emitter and detector.

It should be noted that there is variation from one sensor to another as well as from one Beacon to another. A calibration routine to compensate for these differences is highly recommended when using the Beacon intensity for determining distance to Beacon.