

AD22305 Carrier Revision

Description

The AD22305 is a single axis gyro from Analog Devices capable of sensing rotation at up to $\pm 250^\circ/\text{s}$. This carrier board filters and buffers the signals for direct connection to the Analog Breakout.

This 1"x1" carrier is intended to be mounted with 4-40 hardware. The mounting holes are located at .2"x.8" and .2"x.8".

Copyright (c) 2009 FIRST
Some rights reserved.



This design package is released under the Creative Commons Attribution-Share Alike 3.0 Unported License. For further legal information, see:
<http://creativecommons.org/licenses/by-sa/3.0/>

Consult the FRC Robot Rules before modifying any components. Modifying a component may invalidate its use in the FRC competition and may be dangerous.

Derivative works may or may not be allowed in the FRC competition. Consult the FRC Robot Rules for details.

These design packages are made available primarily to serve as an educational tool. Mentors are strongly encouraged to use them to help their students learn more about electronics.

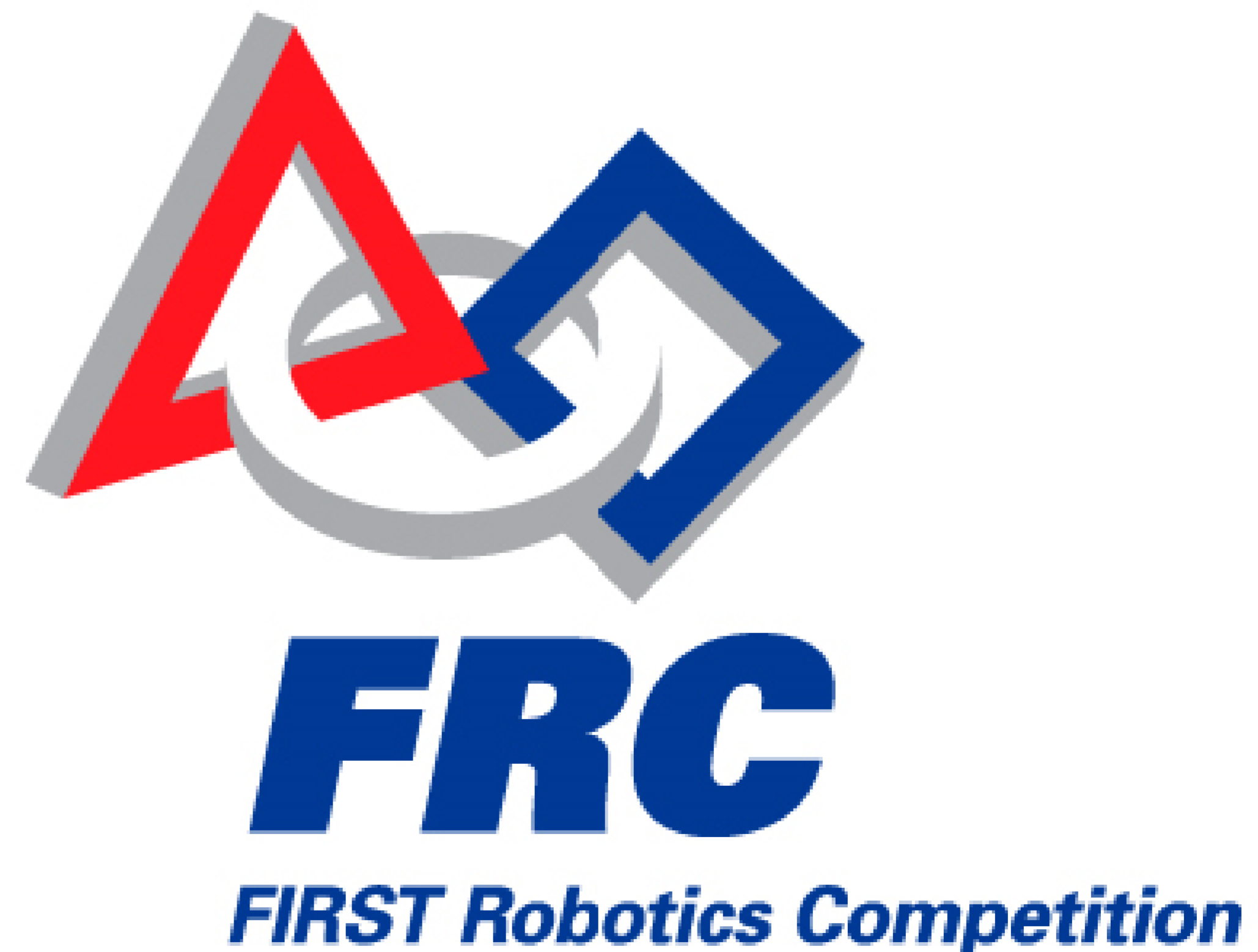

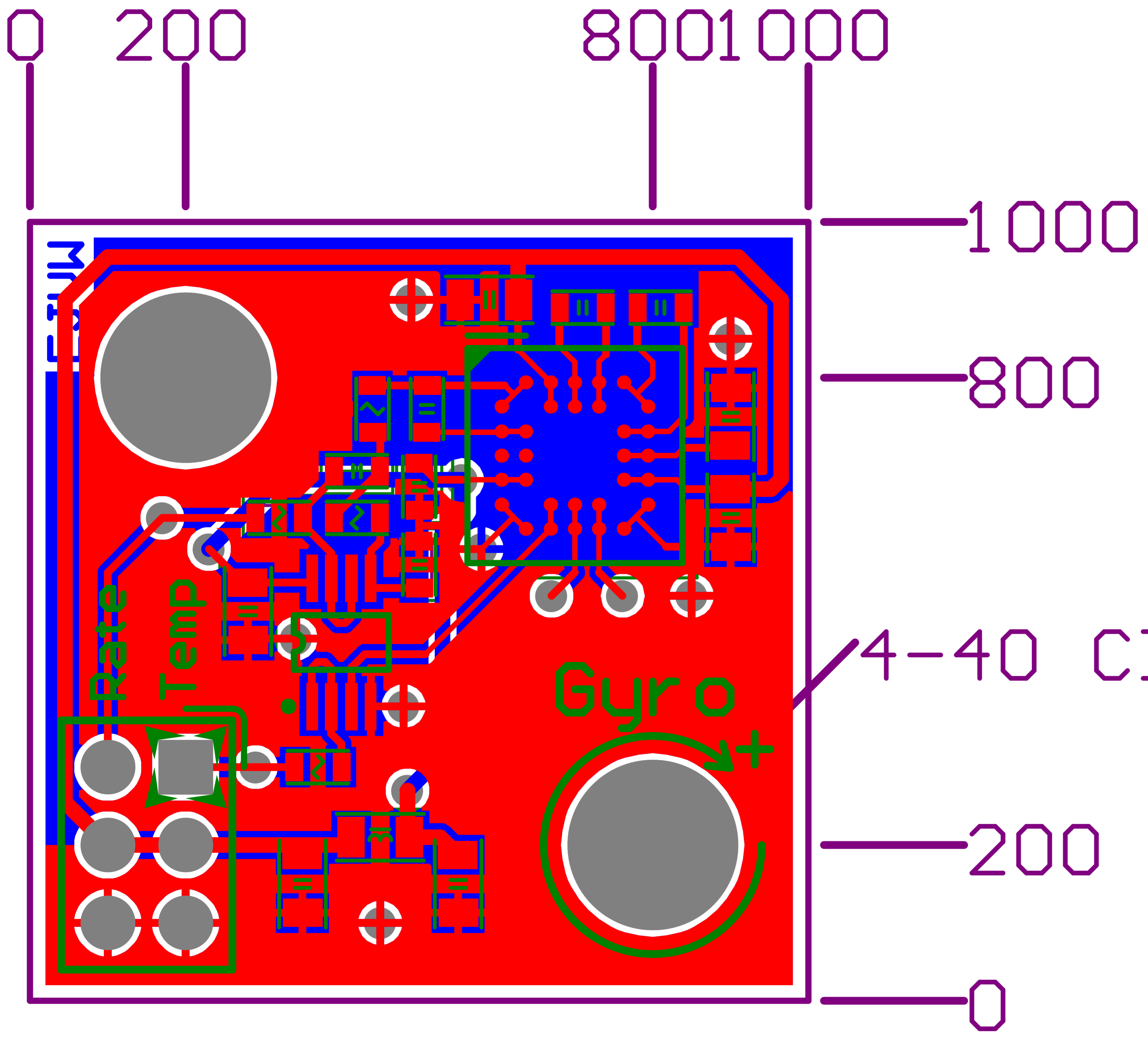

4-40 Clearance, 2PL